

Level sensor

Magnetostrictive, high-resolution measuring principle

For sanitary applications, model FLM-H

TC Fluid Control data sheet LM 20.01



Applications

- Food and beverage industry
- Pharmaceutical industry
- Biotechnology
- Level measurement in fermenters

Special features

- Fully welded and dead space free
- Operating limits:
 - Operating temperature: $T = -40 \dots +250 \text{ }^\circ\text{C}$
 - Operating pressure: $P = \text{Vacuum to } 10 \text{ bar}$
- Insensitive to foaming, ideal for interface measurement
- High-precision level measurement: Accuracy $< 0.5 \text{ mm}$
- Wide variety of hygienic process connections

Description

The model FLM-H magnetostrictive sensor has been specifically designed for the requirements of the food and beverage, pharmaceutical and biotechnology industries. The sensor is particularly suitable for the special conditions of CIP/SIP cleaning processes, such as chemical stability towards cleaning liquids and high temperatures.

The guide tube is directly welded to the process connection, which guarantees a crevice-free connection, additional sealings are not required.

The sensor is supplied with a DC voltage of 10 ... 30 V. Available output signals are 4 ... 20 mA or 4 ... 20 mA with HART® signal.



Level sensor, for sanitary applications, model FLM-H

The hygienically designed sensor housing, with an ingress protection of up to IP 68, offers a secure protection for external cleaning with splash water and enables its use in high-humidity environments.

The model FLM-H sensor fulfils the high demands of sanitary applications. It is marked with the 3-A symbol and current version number, as it conforms, based on a third party verification, to the 3-A standard.

Further special features

- Large range of application due to the simple, proven functional principle
- For harsh operating conditions, long service life
- Continuous measurement of levels, independent of physical and chemical changes of the media such as: Foaming, conductivity, dielectric, pressure, vacuum, temperature, vapours, condensation, bubble formation, boiling effects, density change
- Signal transmission over long distances
- Simple installation and commissioning, onetime calibration only, no recalibration necessary
- Level displayed proportional to volume or height

Options

- Customised solutions

Components of the level sensor, model FLM-H

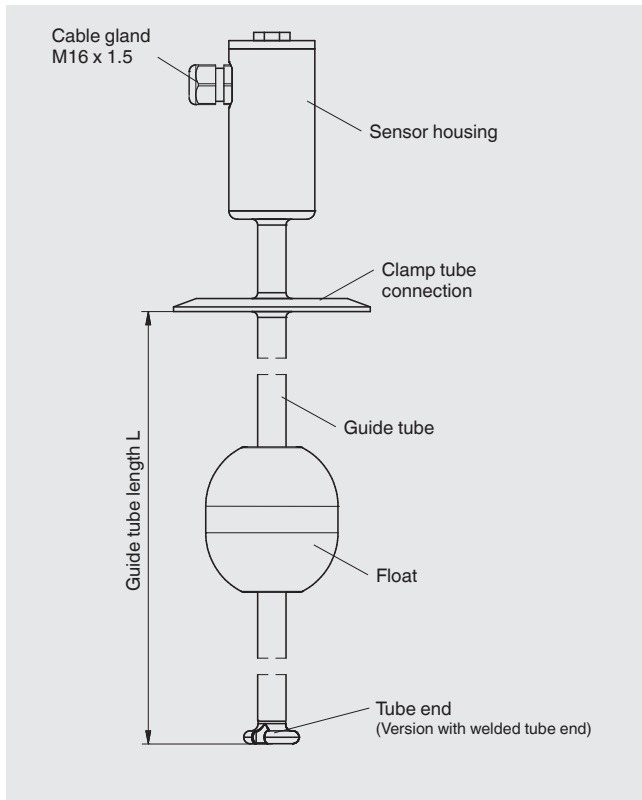
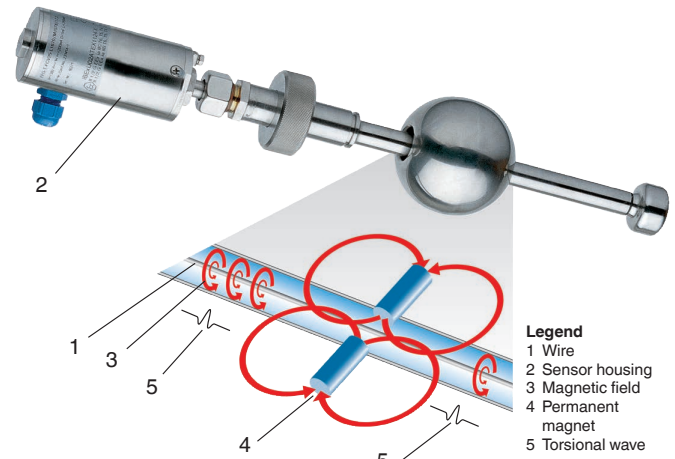

Illustration of the principle



Design and operating principle

- The measuring process is triggered by a current impulse. This current produces a circular magnetic field (3) along a wire (1) made of magnetostrictive material fixed in the guide tube.
- At the point being measured (liquid level) there is a float with permanent magnets (4) acting as a position transducer.
- The interaction of both magnetic fields generates a mechanical torsion wave (5) in the wire.
- This is converted into an electrical signal at the end of the wire in the sensor housing (2) by a piezoceramic converter.
- The measured propagation delay enables the origination point of the mechanical wave, and thus the float position, to be determined with high accuracy.

Overview of the process connections

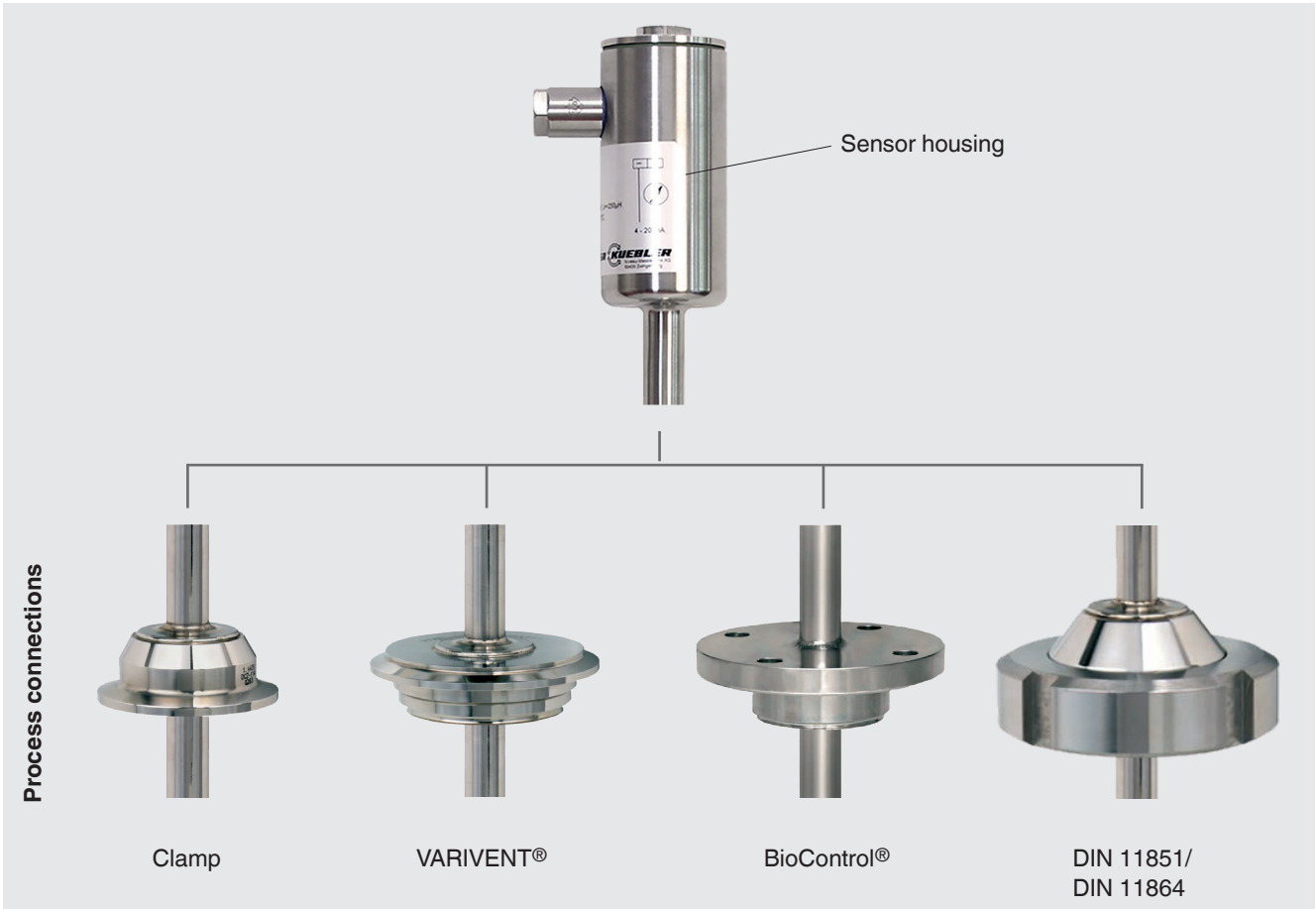

VARIVENT® is a registered trademark of the company GEA Tuchenhagen.
BioControl® is a registered trademark of the company NEUMO.

Tube ends

Version with separate sensor base support

This sensor base support is welded “separately” at the bottom of the tank. When mounting the sensor, the guide tube with the float can be fitted into the sensor base support inside the vessel to fix it. Thus the float is held in position and serves as a position transducer for the level. With stirring movement within the container, the sensor is fixed. Additional advantage: If the lid of the process vessel is large enough and the float can be placed onto the sensor, then small process connections can be used.

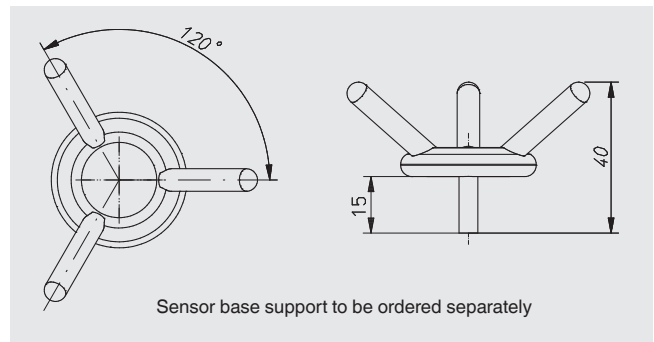

Version with welded pipe end

This tube end is fully welded at the end of the guide tube and offers a dead-space free end to the sensor guide tube. The geometry of the end of the guide tube enables CIP/SIP cleaning. This variant can be selected when the sensor including the float (taking into account the float diameter) can be mounted through the process connection.

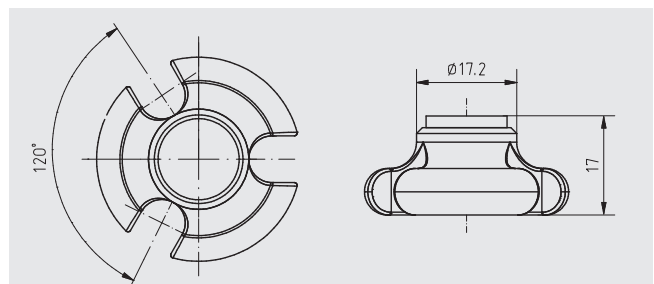

Sensor, sterile version, model FLM-H

Process connection, guide tube and float from stainless steel 1.4435 (316L) or 1.4404 (316L), surface ground and polished $Ra < 0.8 \mu\text{m}$ or $Ra < 0.4 \mu\text{m}$, alternatively electropolished

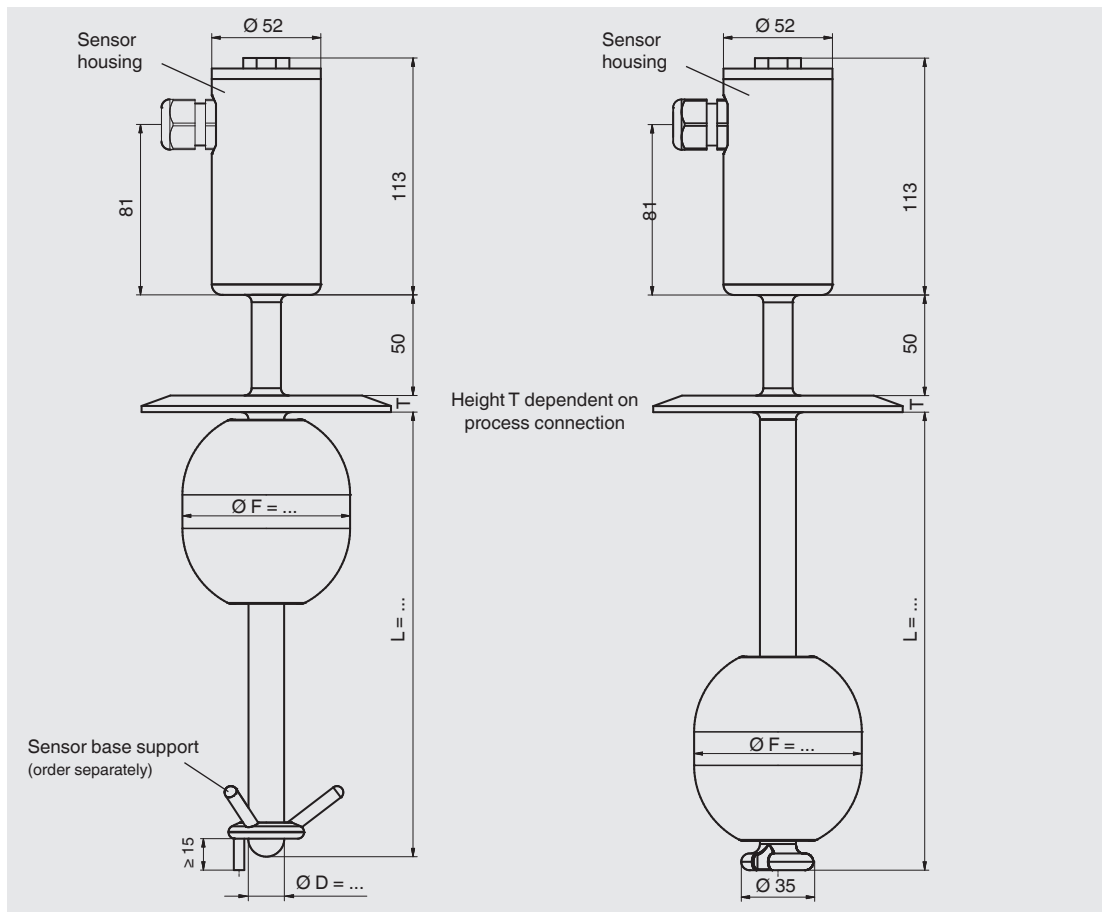

| | Version with separate sensor base support | Version with welded tube end |
|--------------------------|---|--|
| Electrical connection | Sensor housing | Stainless steel 1.4305 with cable gland M16 x 1.5 polyamide or hygienic design |
| Process connection | <ul style="list-style-type: none"> ■ Clamp connection ISO 2852 (DN 32 ... DN 100 or 1.5" ... 4") ■ Clamp connection DIN 32676 (DN 32 ... DN 100 or 1.5" ... 4") ■ Aseptic mounting thread downwards DIN 11864-1 (DN 32 ... DN 100 or 1.5" ... 4") ■ Aseptic collar connecting sleeve DIN 11864-1 (DN 32 ... DN 100 or 1.5" ... 4") ■ Aseptic flange connection DIN 11864-2 (DN 32 ... DN 50 or 1.5" ... 2") ■ Aseptic clamp connection DIN 11864-3 (DN 32 ... DN 100 or 1.5" ... 4") ■ VARIVENT® (form F, N and G) ■ BioConnect® threaded connection (DN 32 ... DN 100 or 1.5" ... 2") ■ BioConnect® flange connection (DN 32 ... DN 100 or 1.5" ... 2") ■ BioConnect® clamp connection (DN 32 ... DN 100 or 1.5" ... 2") | |
| Guide tube diameter | 12, 14 or 17.2 mm (stainless steel 1.4435 or 1.4404, surface ground and polished, $Ra \leq 0.8 \mu\text{m}$ or $Ra \leq 0.4 \mu\text{m}$) | |
| Guide tube length L max. | 6,000 mm | |
| Float | Material stainless steel 1.4435 or 1.4404 Float diameter 50 or 80 mm Float selection depending on guide tube diameter | |
| Density range | Float diameter 50 mm: $1100 \text{ kg/m}^3 \dots 1860 \text{ kg/m}^3$ Float diameter 80 mm: $770 \text{ kg/m}^3 \dots 1162 \text{ kg/m}^3$ | |
| Max. operating pressure | 10 bar | |
| Temperature range | <ul style="list-style-type: none"> ■ Medium standard -40 ... +250 °C ■ Ambient temperature at the sensor housing -40 ... +85 °C ■ Storage temperature: -20 ... +60 °C | |
| Output signal | 4 ... 20 mA, HART® | |
| Power supply | DC 10 ... 30 V | |
| Accuracy | $< \pm 0.5 \text{ mm}$ | |
| Resolution | $< 0.1 \text{ mm}$ | |
| Load | max. 900 Ω at 30 V | |
| Mounting position | Vertical $\pm 30^\circ$ | |
| Ingress protection | IP 68 per EN 60529 / IEC 60529 | |

Certificates (option)

- 2.2 test report
- 3.1 inspection certificate
- 3-A conformity
- Safety Integrity Level (SIL 2)

Ordering information

Model / Version / Cable gland / Process connection / Guide tube diameter / Guide tube length (insertion length) L / 100 % mark L1 / Measuring range (span 0 - 100 %) / Process specifications (operating temperature and pressure, limit density) / Options

© 2014 WIKA Alexander Wiegand SE & Co. KG, all rights reserved.
The specifications given in this document represent the state of engineering at the time of publishing.
We reserve the right to make modifications to the specifications and materials.

TC Fluid Control Head Office

Unit 4 The Interchange, Wested Lane,
Swanley, Kent
BR8 8TE
Tel: +44 (0) 1322 622 400
Fax: +44 (0)1322 660 621
Email: instruments@tc-fluidcontrol.com